



Daruifuno

Conductivity Sensor

Basic User Manual

Model: DEC79

Version 1.0

Contents

Chapter 1 Specification	1
Chapter 2 Basic Information	2
2.1 Security Information.....	2
2.2 Overview.....	2
2.3 Dimension.....	2
Chapter 3 Installation	3
3.1 Sensor Installation.....	3
3.2 Sensor Wiring.....	4
Chapter 4 Use	5
4.1 Communication.....	5
4.2 Read Measurements.....	5
4.3 Sensor Calibration.....	5
4.3.1 Two Points Calibration.....	5
4.3.2 Multi-point Calibration.....	6
4.3.3 Temperature Correction.....	6
4.4.4 Reset Calibration.....	6
Chapter 5 Maintenance	7
5.1 Maintenance Cycle.....	7
5.2 Cleaning.....	7
Appendix A Modbus Register Information	

Guarantee

Our company seriously warrants each of the instrument for one year (12 months) from the specific date of delivery. Consumables and consumable parts in the equipment are not covered by the warranty. The terms of this warranty shall not apply if damage to the instrument occurs beyond the warranty period, or in the opinion of the company, the breakage or destruction of the instrument is due to improper use, lack of maintenance, improper installation, improper modification, abnormal environmental conditions, etc. The company's obligation under this warranty is limited to providing replacement or repair of this product, as the case may be. The product must be thoroughly cleaned to remove any contaminated chemicals before it is accepted for replacement or repair. Our obligations shall not exceed the price of the product itself. In no event shall the company be liable for damage caused by incidental or consequential damages, whether to persons or objects. The company shall not be liable for any other loss, damage or expense of any kind, including economic loss resulting from the installation, use or improper use of the product.

- For details, please refer to the product's quality promise with the product, and keep this manual and the quality promise properly.

Chapter 1 Specification

Product specifications are subject to change without notice.

Measuring Principle	Graphite two electrode measurement principle
Measuring Range	0~20uS/cm, 20~200uS/cm, 200~2000uS/cm, 2~10mS/cm 0.0~50.0℃
Resolution	0.01uS/cm 、 0.1uS/cm 、 1uS/cm 0 1℃
Accuracy	±1.0%FS
Temp Compensation	0~50℃, NTC automatic or manual
Calibration Method	Deviation correction, factor correction, multi-point calibration
Working Temperature	0~50℃
Working Pressure	≤6bar
Protection Grade	IP68
Power Supply	9~36VDC
Power Consumption	About 0.2W
Electrical isolation	Power and communication are isolated inside the sensor
Communication Interface	RS485 MODBUS
Shell Material	ABS
Dimension	φ35mm, total length 260mm (include cleaning cover)
Installation Size	One inch 1" NPT thread at both ends Insertion depth 100mm (including cleaning connector 115mm)
Weight	About 150 (not include the cable)
Cable	PUR (polyurethane) sheath, standard 5 meters, length can be customized
Connection Method	Default bare wire, M12 plug or waterproof aviation plug to be customized

Chapter 2 Basic Information

2.1 Security Information

Please read this manual completely before unpacking, installing and operating this equipment. Pay special attention to all precautions. Otherwise, it may cause serious personal injury to the operator or damage the equipment.

2.2 Overview

The sensor is based on the principle of two-electrode measurement. Two polar plates parallel to each other are put into the measured solution, and a driving voltage is applied to both ends of the polar plates. The conductivity of the solution is measured according to the current intensity between the polar plates.

The sensor electrode plate is made of graphite material, which can minimize the polarization effect and ensure the measurement accuracy. The sensor measurement unit is designed for replacement structure, which reduces the replacement and maintenance costs of users during use.

The sensor is suitable for sewage plants, water plants, water stations, surface water, environmental protection water treatment, metallurgical electronics, mining, paper industry, semiconductors and other fields. It can continuously monitor the conductivity of aqueous solutions.

2.3 Dimensions

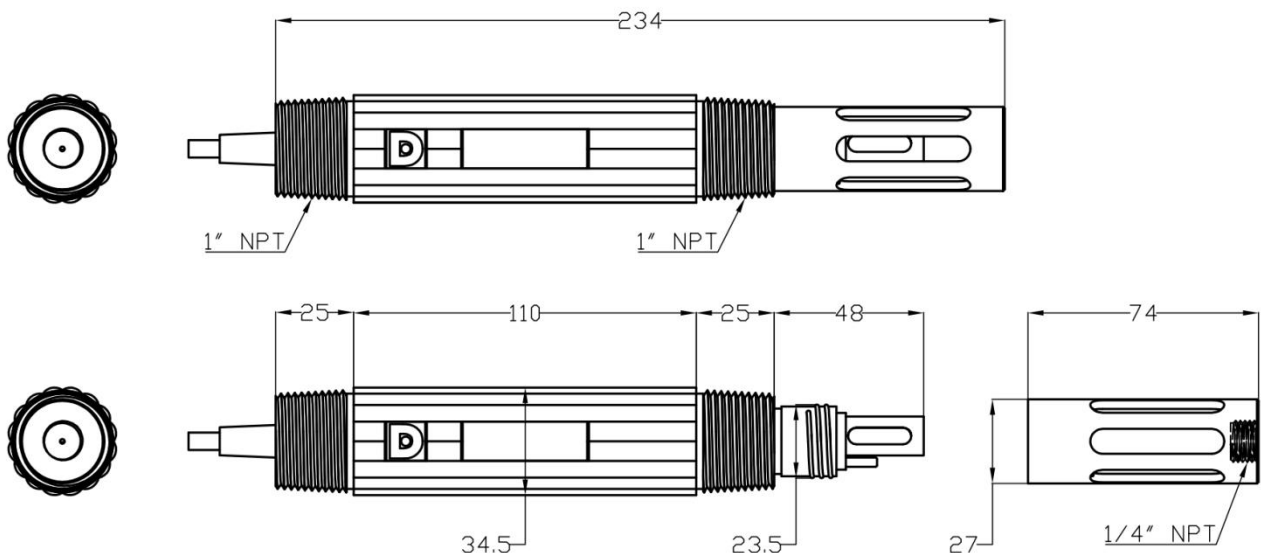

Figure 1 Dimensions of the sensor

Chapter 3 Installation

3.1 Sensor Installation

Refer to the pictures in this section to install and fix the sensor. To ensure that the sensor can measure safely and accurately, the following conditions must be met during installation:

- In pipeline installation, the sensor should be installed at a low position in the pipeline, with a stable flow rate and not prone to air bubbles;
- In the case of submerged installation, the front section of the sensor should be installed facing the direction of the water flow, and should go deep into the active water body;
- The measuring part of the sensor must be kept clean during installation. Do not touch the inner surface of the electrode with your hands or dirty objects. After touching oily or glue-like objects, it will not be able to accurately measure for a long time;
- It is forbidden for the sensor wire to be threaded and bound together with the power line to avoid interference with the measurement or breakdown of the sensor measurement unit when it is damaged.

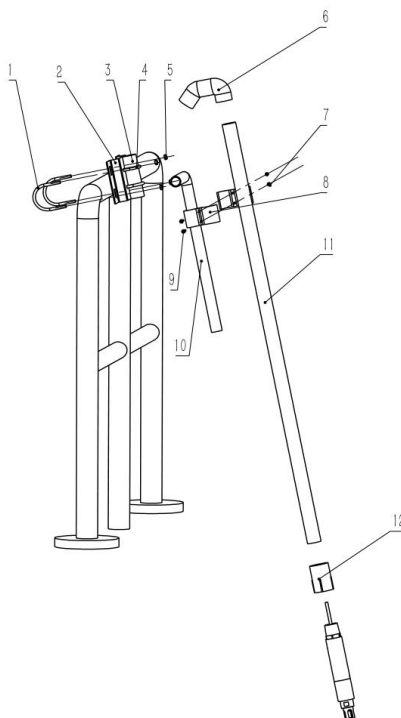

Figure 2 Schematic diagram of railing installation

1-DN60U card	7-M48 Nut*4
2-plate	8-Eight-character clip 25&32
3-Handle sleeve	9-M4*25 screw*2
4-DN40U card	10-handle
5-M6 Nut*8	11-DN32PVC Bracket
6-Rainproof elbow	12-1 inch inner wire straight pipe joint

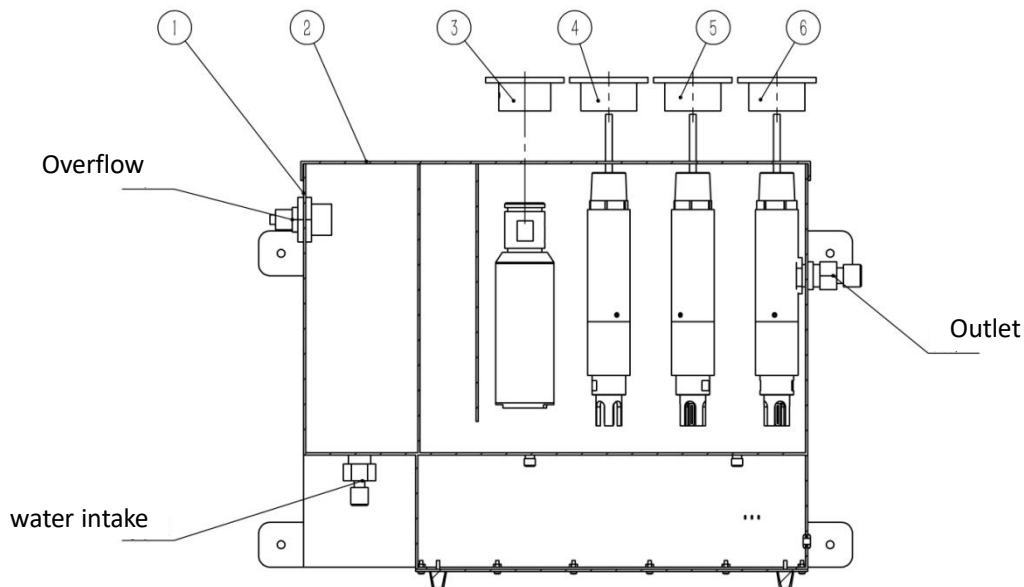

Figure 3 Schematic diagram of installation of five-parameter flow cell

1-Flow cell	4-pH sensor fixed connection cover
2-Flow cell cover	5-DO sensor fixed connection cover
3-Turbidity sensor fixed connection cover	6-Conductivity sensor fixed connection cover

3.2 Sensor Wiring

The sensor is correctly connected as defined in the table below.

Wire Color	Red	Black	White	Green
Terminal Definition	+12V DC	Power ground	RS485 data A (+)	RS485 data B (-)
Instrument Terminal Symbols	V+	V-	AS	BS

Chapter 4 Use

4.1 Communication

The sensor communication is RS485 Modbus-RTU, please refer to Modbus related protocol description for specific communication protocol.

The default communication parameters of the sensor are: communication address=17, baud rate=9600, parity bit=none, stop bit=1 bit, the information parameters can be modified by referring to the register description in Appendix A

4.2 Read Measurements

Sensor measurements can be read by connecting the meter or using other Modbus master devices.

Please refer to Appendix A for the Modbus register address of the device.

The sensor measurement data is 4-byte floating point data, and the data sequence is little endian-byte exchange, pay attention to the conversion order.

4.3 Sensor Calibration

The sensor provides two measurement calibration methods, two-point calibration and multi-point calibration. Normally, two-point calibration can meet daily calibration and maintenance. When the sensor measurement deviation is large or the measurement unit is replaced, multi-point calibration is required.

4.3.1 Two Points Calibration

The two-point calibration corrects the sensor measurement value through the "deviation value" and "factor value". The relationship between the sensor measurement value and the two parameters is as follows:

$$\text{Conductivity measurement} = (\text{original measurement} + \text{deviation}) * \text{factor}$$

Two-point calibration requires the preparation of two water samples with known conductivity values. The calibration process is as follows:

- Use the 06 function code to write the value 33 to the No. 33 register to restore the calibration;
- Put the sensor into the water sample 1, and gently shake the sensor to ensure that no air bubbles affect the measurement at the measuring end of the sensor. After the value is stable, record the measured 1;
- Rinse the sensor with pure water and absorb the residual moisture with filter paper. Put the sensor in water sample 2 and shake the sensor gently. After the value is stable, record the measured 2;
- Calculate the deviation value and factor value
- $\text{Factor} = (\text{water sample value 2} - \text{water sample value 1}) / (\text{measured 2} - \text{measured 1})$
- $\text{Deviation value} = (\text{water sample value 1} / \text{factor}) - \text{measured value 1}$
- Use the 16 function code to write the deviation value and factor value into the corresponding register

4.3.2 Multi-point Calibration

Multi-point calibration requires preparation of four standard solutions: 84uS, 146uS, 1413uS, and 12880uS. The calibration process is as follows:

- Use deionized water to clean the electrode and absorb the residual moisture with filter paper. Place the electrode in dry air and wait for the measured value to stabilize. Use the 16 function code to write a value of 0 to the 23 register;
- Use deionized water to clean the electrode and absorb the residual water with filter paper. Place the electrode in the 84uS/cm conductivity standard solution, wait for the electrode measurement to stabilize, use the 16 function code, and write the value 84 to the 25 register;
- Use deionized water to clean the electrode and absorb the residual moisture with filter paper. Place the electrode in the 146uS/cm conductivity standard solution, wait for the electrode measurement to stabilize, use the 16 function code, and write the value 146 to the 27 register;
- Use deionized water to clean the electrode and absorb the remaining moisture with filter paper. Place the electrode in a 1413uS/cm conductivity standard solution, wait for the electrode to measure stable, use the 16 function code, and write the value 1413 to the 29 register;
- Use deionized water to clean the electrode and absorb the residual water with filter paper. Place the electrode in the 12880uS/cm conductivity standard solution, wait for the electrode to measure stable, use the 16 function code, and write the value 12880 to the 31 register;

Note: When calibrating, it is recommended to calibrate at 25°C, otherwise a small amount of temperature compensation error will be introduced.

Tip: The sensor supports up to 5 points of calibration, and the user can select the calibration point according to the application.

4.3.3 Temperature Correction

Temperature correction provides the function of adjusting temperature deviation. The calculation method of temperature deviation is as follows:

$$\text{Temperature deviation value} = \text{actual temperature value} - \text{temperature measured}$$

4.3.4 Reset Calibration

Use the function code 06 to write the value 33 to the No. 33 register to restore the sensor calibration parameters to the factory state.

Chapter 5 Maintenance

The sensor contains precision photoelectric components. Please make sure that the sensor will not be subject to any strong mechanical impact during use. There are no user maintenance parts inside the sensor.

5.1 Maintenance Cycle

Maintenance work	Maintenance frequency
Visual inspection	Every month
Check calibration	Monthly (according to the environmental conditions of use)

5.2 Cleaning

During routine cleaning, the sensor can be cleaned by shaking it in clean water. If the surface of the sensor measuring part is seriously polluted, the sensor measuring part can be soaked in light detergent or weak acid for 15 minutes, and then the electrode can be cleaned with distilled water.

Note: During installation and cleaning, do not use hard objects to touch the surface of the measurement electrode, let alone wipe the surface of the electrode with any objects, otherwise the measurement will be inaccurate and need to be recalibrated, which will affect the measurement range of the sensor in severe cases.

Appendix A Modbus Register Information

Item	Register	Data Type	Length	Access Type	Function Code	Description
State	0	Unsigned integer	1	Read	04	Non-zero means the sensor is performing calibration
Conductivity measure	2	Floating point	2	Read	04	Output value unit:uS/cm
Temperature measure	4	Floating point	2	Read	04	Temperature measurement value, unit: °C
Salinity value	6	Floating point	2	Read	04	Calculated value of salinity, unit: ppt
TDS value	8	Floating point	2	Read	04	TDS calculated value, unit: ppm
Serial number	10	String	6	Read	04	Serial number 12-bit ASCII code
Firmware version	16	Unsigned integer	1	Read	04	version number x100
Address	0	Unsigned integer	1	Read/write	03/06	Communication address range 1~254, default 17
Baud rate	1	Unsigned integer	1	Read/write	03/06	0=4800,1=9600(default), 2=19200,3=38400
Check Digit	2	Unsigned integer	1	Read/write	03/06	0=no (default), 1=Odd, 2=Even
Stop bit	3	Unsigned integer	1	Read/write	03/06	1=1STOP (default) , 2=2STOP
Average times	4	Unsigned integer	1	Read/write	03/06	0=2 times (default), 1=4 times, 2=8 times, 3=16 times, 4=32 times
Range setting	5	Unsigned integer	1	Read/write	03/06	0=auto (default), 1=20uS/cm, 2=200uS/cm, 3=2000uS/cm, 4=10000uS/cm
Temperature mode	6	Unsigned integer	1	Read/write	03/06	0=auto, 1=manual
Conductance deviation	7	Floating point	2	Read/write	03/16	Deviation value default 0.0 uS/cm
Conductivity factor	9	Floating point	2	Read/write	03/16	Factor correction default value 1.0
Manual temp value	11	Floating point	2	Read/write	03/16	Default 25°C
Temp deviation	13	Floating point	2	Read/write	03/16	temp deviation value default 0.0°C
Cell constant	15	Floating point	2	Read/write	03/16	Default 1.0
TDS Conversion factor	17	Floating point	2	Read/write	03/16	Default 0.5
Temp Compensation Coefficient	19	Floating point	2	Read/write	03/16	Default 1.85%/°C

Appendix

Item	Register	Data Type	Length	Access Type	Function Code	Description
Zero point CAL	21	Floating point	2	Write	03/16	Write 0 to perform zero point calibration
Point 1st CAL	23	Floating point	2	Read/write	03/16	Write the calibration solution value to start calibration, 84uS/cm
Point 2nd CAL	25	Floating point	2	Read/write	03/16	Write the calibration solution value to start calibration, 146uS/cm
Point 3rd CAL	27	Floating point	2	Read/write	03/16	Write the calibration solution value to start calibration, 1413uS/cm
Point 4th CAL	29	Floating point	2	Read/write	03/16	Write the calibration solution value to start calibration, 4239uS/cm
Point 5th CAL	31	Floating point	2	Read/write	03/16	Write the calibration solution value to start calibration, 12880uS/cm
Reset CAL	33	Unsigned integer	1	Write	06	Write 33 to resume calibration

Note 1: When the parity bit is set to "None", the stop bit can be set to 1STOP/2STOP; when the parity bit is set to "Odd" or "Even", the stop bit can only be set to "1STOP".



Delfino Environmental Technology Co., Ltd.

www.daruifuno.com

info@daruifuno.com